

ELRINGKLINGER GROUP

**Energiewende: Transformation eines  
Traditionsunternehmens 26.09.2024**

**H2-Wandel Fachtagung – IHK  
Reutlingen**

The image shows the exterior of a building with a large, three-dimensional logo for 'elringklinger'. The logo consists of the company name in a bold, sans-serif font, with the letters 'e', 'l', 'i', 'n', 'g', 'k', 'l', 'i', 'n', 'g', 'e', 'r' raised from the wall. To the right of the name is a stylized, curved graphic element that resembles a partial circle or a swoosh, also rendered in a three-dimensional, metallic-looking finish. The building's facade is light-colored and appears to be made of concrete or stone. In the background, a glass entrance is visible, reflecting the sky and surrounding environment.

**Dies ist keine offizielle Firmenpräsentation**

# different know-how

TWO COMPANIES WITH COMPLEMENTARY  
EXPERTISE AND VISIONS

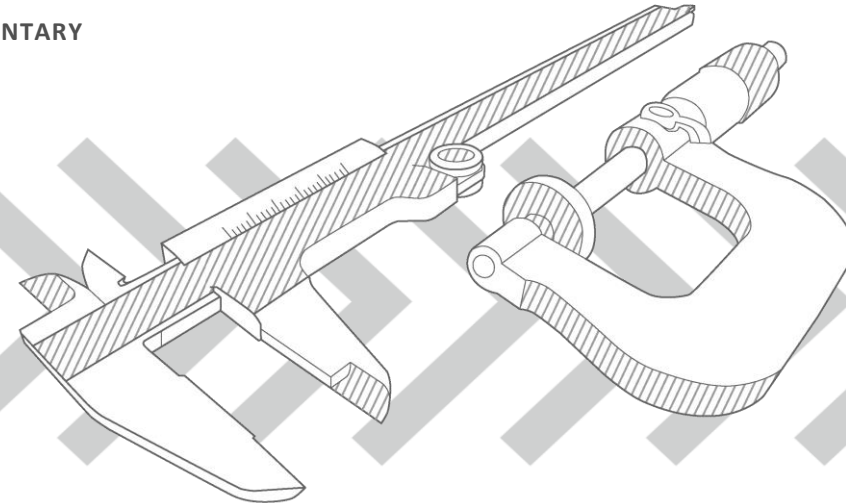
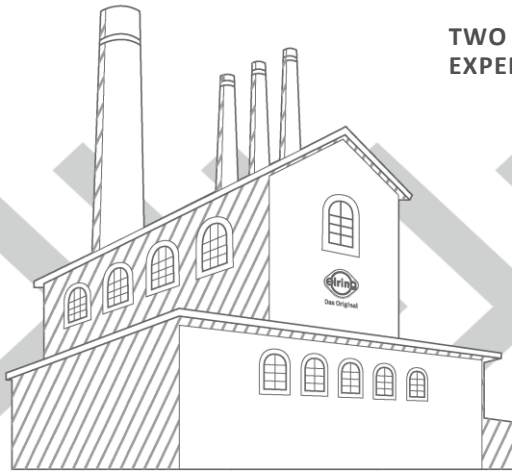

Das Original

MANUFACTURER



ENGINEER

# 145 years of experience and solid shareholder structure

- **1879** Paul Lechler establishes a merchandising business in Stuttgart for technical products and gaskets.
- **1885** Richard Klinger establishes an engineering office in Vienna.
- **1924** The first Lechler cylinder-head gaskets are produced.
- **1964** Elring production and development moves from Stuttgart to Dettingen/Erms.
- **1993** Elring goes to Asia: The joint venture Changchun Elring Gaskets Co. Ltd. has been founded.
- **1994** Elring GmbH merges with Automotive Division of Richard Klinger GmbH to ElringKlinger GmbH.
- **1997** ElringKlinger founds new plants in UK, Brazil, Mexico, and the U.S.
- **2000** ElringKlinger GmbH merges with parent company ZWL Grundbesitz- und Beteiligungs-AG and is renamed as ElringKlinger AG.
- **2001** ElringKlinger AG intensifies R&D work on fuel cell components, especially on its internal sealing.
- **2002** Registered shares of ElringKlinger AG are traded at Frankfurt and at Stuttgart Stock Exchange.
- **2010** ElringKlinger AG receives its first order for series production of cell contact systems used in lithium-ion batteries.
- **2013** ElringKlinger AG acquires tool maker Hummel Formen GmbH which enables the company to offer structural lightweight components.
- **2017** ElringKlinger AG acquires a stake in hofer powertrain and thus, extends its portfolio to alternative

combined to become a  
**visionary company**



A VISIONARY WITH A PEDIGREE OF SUCCESS

**Dies ist keine offizielle Firmenpräsentation**

# Megatrends trigger technological transformation process



# Where do we come from?

from  
gaskets

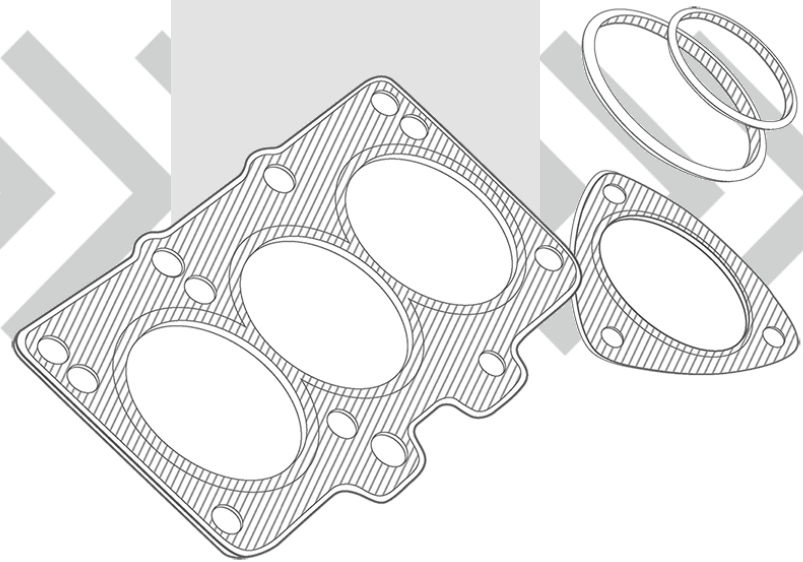

to  
e-mobility

- BATTERY TECHNOLOGY
- FUEL CELLS
- ELECTRIC DRIVE UNIT

and  
lightweight

- PLASTIC MODULES
- POLYMER METAL HYBRIDS
- STRUCTURAL COMPONENTS

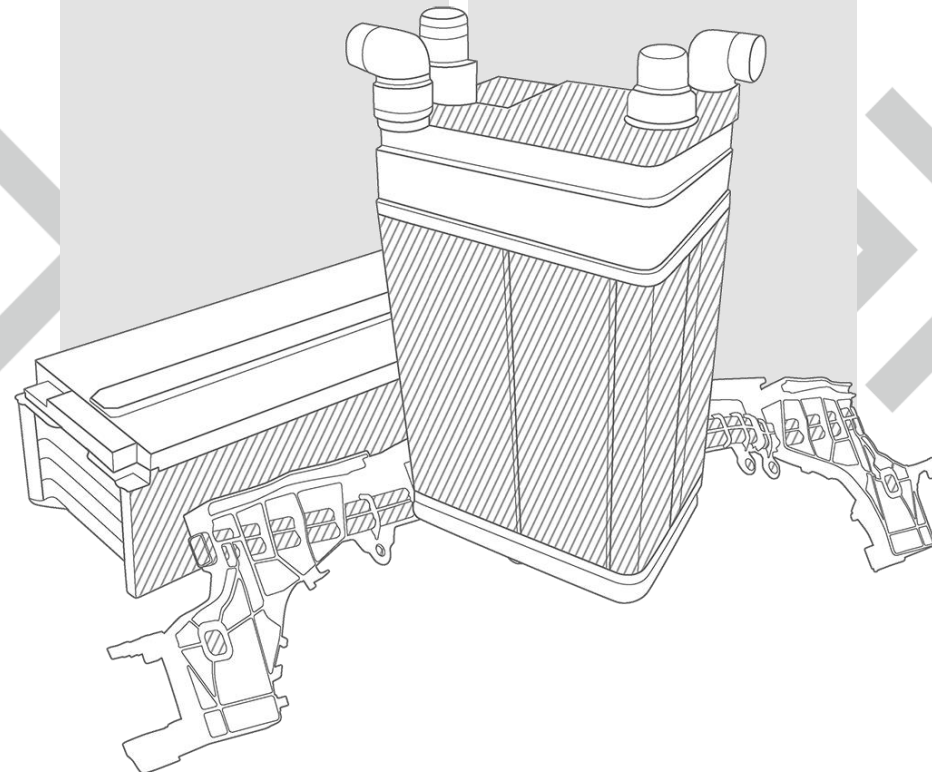



# Current portfolio



BACKGROUND

# Transformation - hydrogen

## The FEAR!???

„Blick zurück“: Wasserstoff-Explosion bei Heraeus Quarzglas am 5. Oktober 1991 – „Tausende Schutzengel über Hanau“



→ **ALWAYS**  
choose the  
**RIGHT**  
sealing!



„Blick zurück“: Wasserstoff-Explosion bei Heraeus Quarzglas am 5. Oktober 1991 – „Tausende Schutzengel über Hanau“ - Erlensee Aktuell ([erlensee-aktuell.com](http://erlensee-aktuell.com)); Smiley Gesicht Glücklich Daumen - Kostenlose Vektorgrafik auf Pixabay

**Dies ist keine offizielle Firmenpräsentation**



# Where are we going to?

## INTO TRANSFORMATION

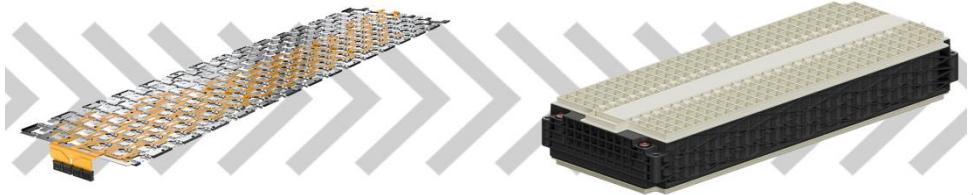
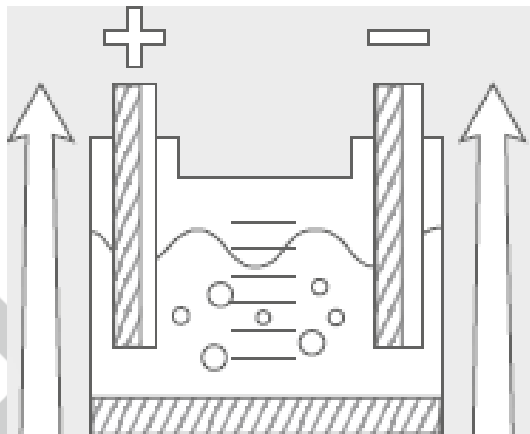

Kunststoffe in einem integrierten Medienmodul

EKPO FUEL CELL TECHNOLOGIES

### Media module of PEMFC stack

Motivation: Integration of system scope close to the stack

- / Reduced system complexity
- / Optimized stack operation
- / Compact system packaging
- / Increased safety aspects

Plastic materials in use:

- / PPA GF35
- / PA9T GF35
- / PA66 GF35

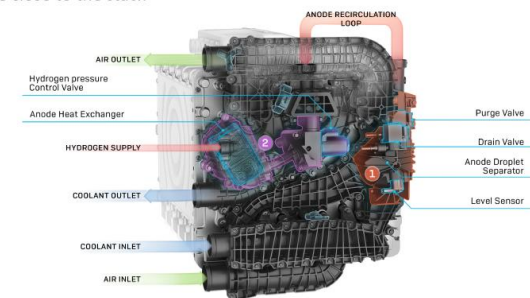
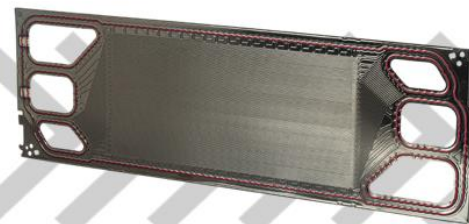

# 145 years of SEALING and GASKET technology

## History and the way into H2-solutions:

- (Metal) sealing solutions: > 140 years
- Engineered plastics: > 50 years
- Metal-Elastomer-Gasket: > 30 years
- Fuel-cell sealing: > 20 years
- Electrolyzer sealing: > 2 year

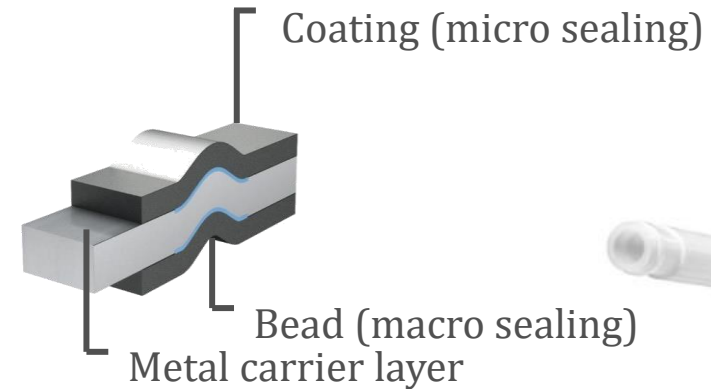

Block profile molded on the front

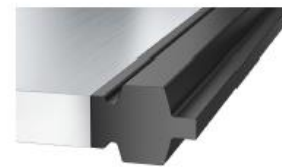

Sealing lip molded onto the carrier



Sealing lip molded onto the carrier

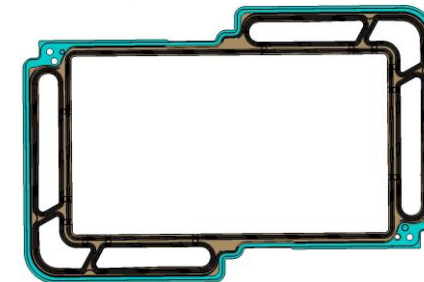
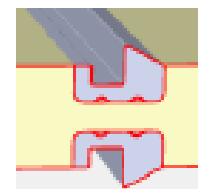

# Production worldwide



## NORTH AMERICA

- CANADA**  
Leamington
- USA**  
Plymouth  
Southfield  
Buford  
Fremont  
Fort Wayne  
San Antonio
- MEXICO**  
Toluca

## SOUTH AMERICA

- BRAZIL**  
Piracicaba

## AFRIKA

- SOUTH AFRICA**  
Johannesburg

## EUROPE

- GERMANY**  
Dettingen/Erms  
Langenzenn  
Runkel  
Geretsried-Gelting  
Thale  
Lenningen  
Bietigheim-Bissingen  
Heidenheim  
Mönchengladbach  
Idstein  
Rottenburg am Neckar  
Neuffen

## GREAT BRITAIN

- Redcar  
Gateshead  
Warwick

## FRANCE

- Nantiat  
Chamborêt  
Poissy

## SWITZERLAND

- Sevelen

## SPAIN

- Reus

## ITALY

- Settimo Torinese

## HUNGARY

- Kecskemét-Kádafalva

## ROMANIA

- Timisoara

## TURKEY

- Bursa

## ASIA

### PR CHINA

- Changchun  
Suzhou  
Qingdao  
Chongqing

### SOUTH KOREA

- Gumi

### JAPAN

- Takasaki  
Tokyo  
Saitama

### INDIA

- Ranjangaon

### INDONESIA

- Karawang

### THAILAND

- Bangkok

“Local for local” – sustainability and net carbon neutrality

Dies ist keine offizielle Firmenpräsentation

# At a glance

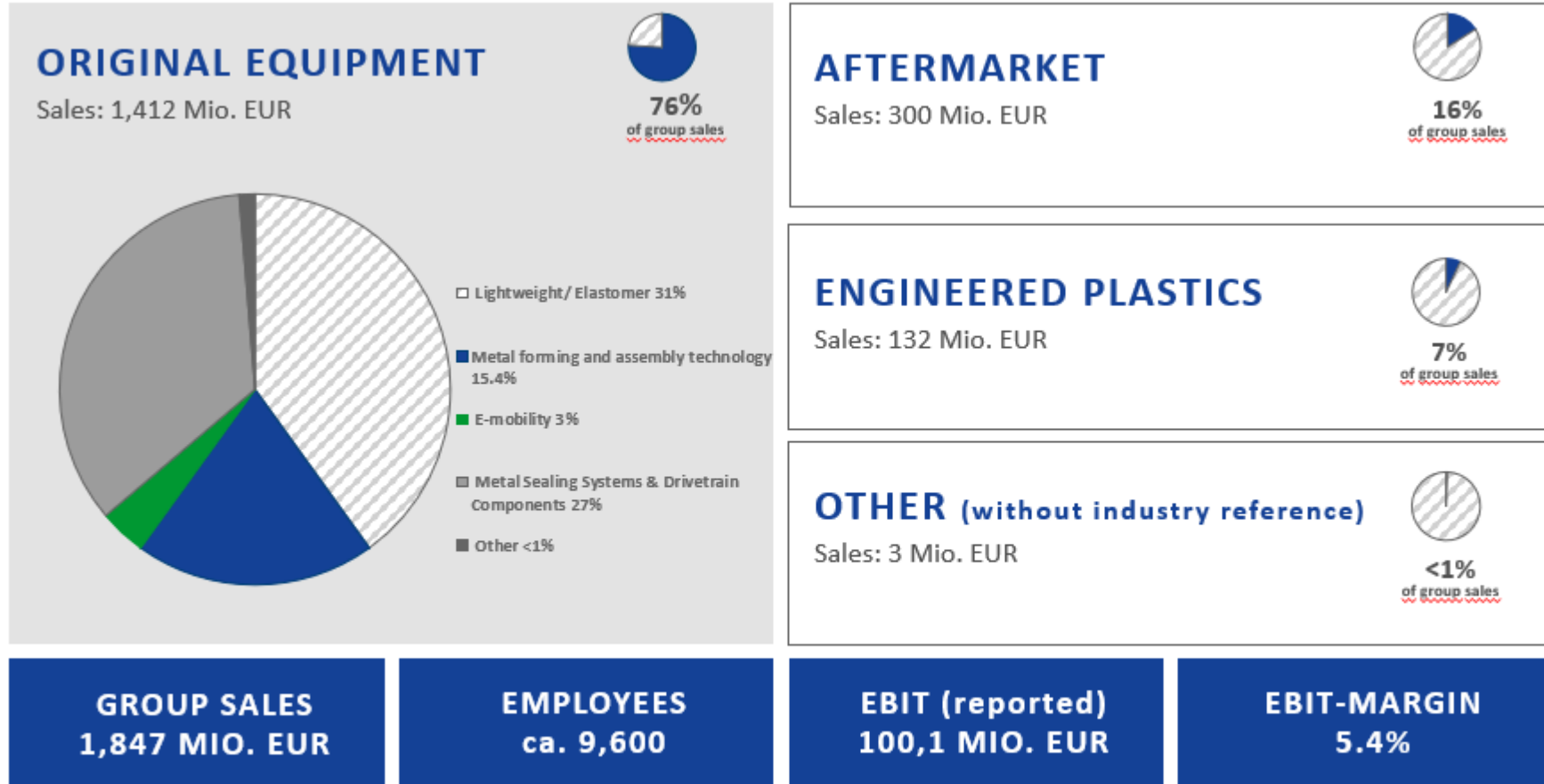

AS OF DECEMBER 31, 2023



# Development process

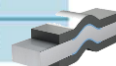

# Utilizing 145 years of know-how in MATERIALS

	Alkaline	PEM	AEM	Solid Oxide
Operating temperature	70-90 °C ✓	50-80 °C ✓	40-60 °C ✓	700-850 °C ✓
Operating pressure	1-30 bar ✓	< 70 bar ✓	< 35 bar ✓	1 bar ✓
Electrolyte	Potassium hydroxide (KOH) 5-7 molL <sup>-1</sup>	PFSA membranes	DVB polymer support with KOH or NaHCO <sub>3</sub> 1molL <sup>-1</sup>	Yttria-stabilized Zirconia (YSZ)
Separator	ZrO <sub>2</sub> stabilized with PPS mesh	Solid electrolyte (above)	Solid electrolyte (above)	Solid electrolyte (above)
Electrode / catalyst (oxygen side)	Nickel coated perforated stainless steel	Iridium oxide	High surface area Nickel or NiFeCo alloys	Perovskite-type (e.g. LSCF, LSM)
Electrode / catalyst (hydrogen side)	Nickel coated perforated stainless steel	Platinum nanoparticles on carbon black	High surface area nickel	Ni/YSZ
Porous transport layer anode	Nickel mesh (not always present)	Platinum coated sintered porous titanium	Nickel foam	Coarse Nickel-mesh or foam
Porous transport layer cathode	Nickel mesh	Sintered porous titanium or carbon cloth	Nickel foam or carbon Cloth	None
Bipolar plate anode	Nickel-coated stainless steel	Platinum-coated titanium	Nickel-coated stainless steel	None
Bipolar plate cathode	Nickel-coated stainless steel	Gold-coated titanium	Nickel-coated Stainless steel	Cobalt-coated stainless steel
Frames and sealing	PSU, PTFE, EPD ✓	PTFE, PSU, ETFE ✓	PTFE, Silicon ✓	Ceramic glass 

Note: Coloured cells represent conditions or components with significant variation among different companies.  
 PFSA = Perfluoroacidsulfonic; PTFE = Polytetrafluoroethylene; ETFE = Ethylene Tetrafluorethylene; PSF = poly (bisphenol-A sulfone); PSU = Polysulfone; YSZ = yttrium-stabilized zirconia; DVB = divinylbenzene; PPS = Polyphenylene sulfide; LSCF = La<sub>0.8</sub>Sr<sub>0.2</sub>Fe<sub>0.8</sub>O<sub>3</sub>; LSM = (La, Sr)<sub>1-x</sub>MnO<sub>3</sub>; Crofer 22APL with co-containing protective coating.  
 Based on IRENA analysis.

## Material-development:

**Polytetraflon™ PTFE, modified PTFE, PTFE composites, Moldflon™ PTFE, TFA, FEP, ETFE, PVDF, PEEK, PPS, PPSU, PEI and PE-UHMW, NBR, FPM, EPDM**

Our materials and products meet the toughest demands required in the field – economical, sustainable and safe.

# Utilizing 145 years of know-how for new demands

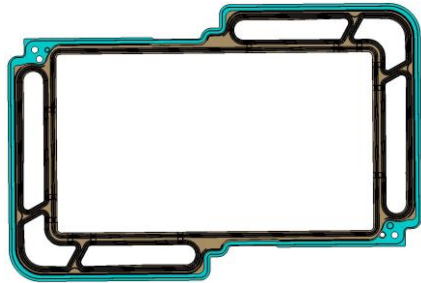

Seal on GDL

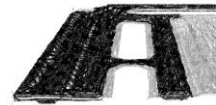

Bi-Polar plates with integrated seal

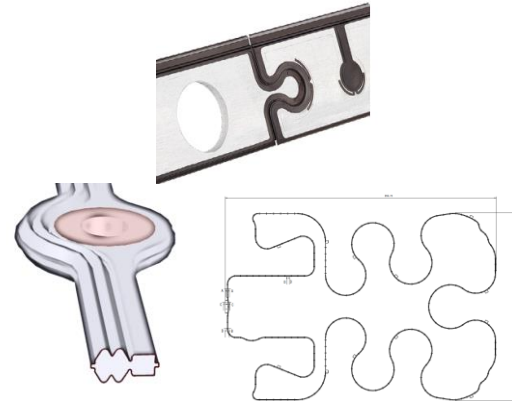

Large scale sealing solutions (Metal-Elastomer)

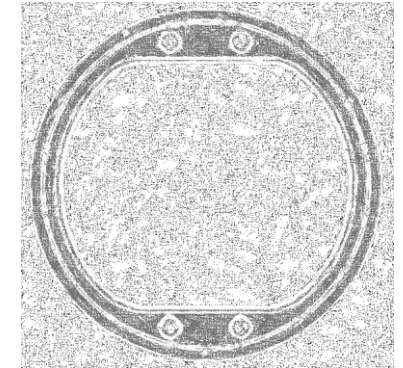

1 and NEW 2 component sealing

## Sealing Solutions for Electrolysis and Energy Storage

incl. design, FEA/simulation, tooling, prototyping, testing and series production

# Utilizing 145 years of know-how for new demands

Usual sealing design solutions and serial realization:

Sealing on a dedicated frame:

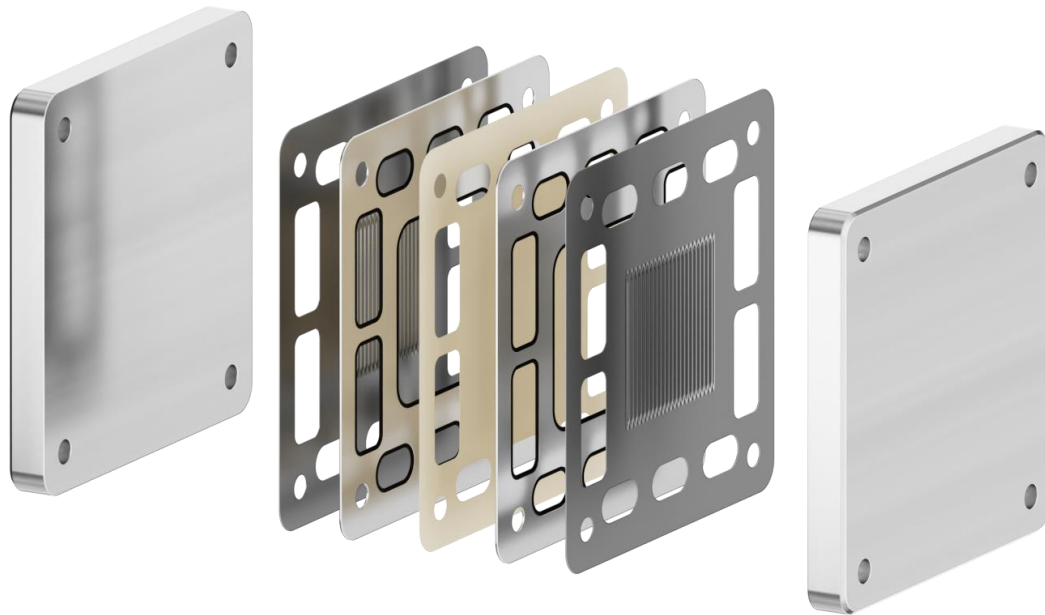

Sealing on the bipolar-plate:

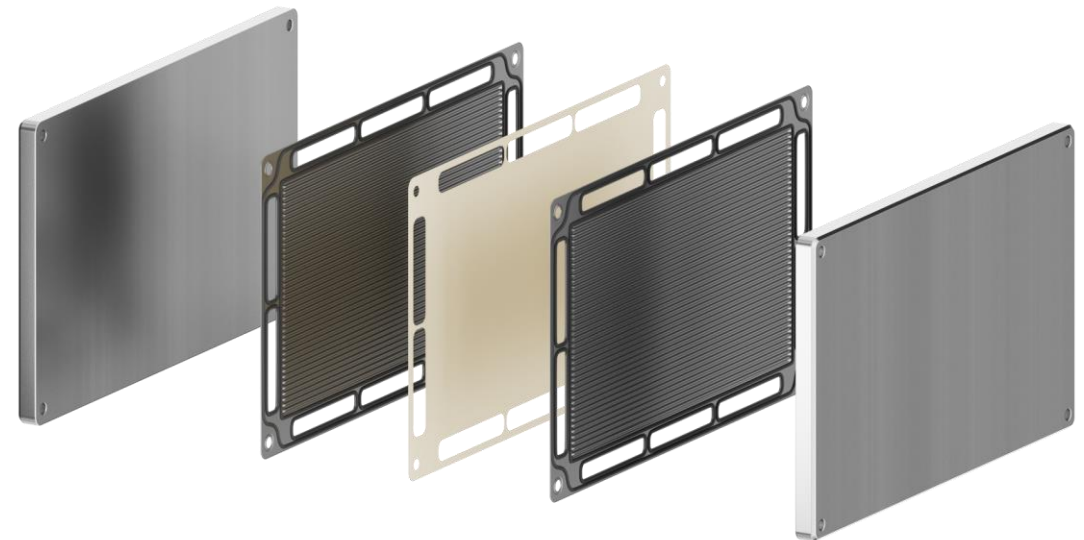



EKPO FUEL CELL TECHNOLOGIES

# Success Story



EKPO supplies NM5-EVO and NM12 stacks to partners for high power fuel cell systems

/ **NM12-Twin** stack boasts a market leading power of over **200 kW** for heavy duty on-/off-road, racing, marine and stationary applications



EKPO fuel cell stacks chosen by Airbus to realize zero emission aviation

/ Development of hydrogen propulsion system including fuel cells for aircraft in a strategic partnership with **Airbus**



Leading OEM's trust in EKPO development and mass production competences

/ Development of highest power density fuel cell stacks and components for mass production **OEM projects**



**Press Release**

EKPO has received an order from a major European OEM to develop and supply bipolar plates

Dettingen/Erms (Germany), September 20, 2022

**Press Release**

EKPO to develop and supply fuel cell stacks for a European OEM

Dettingen/Erms (Germany), February 02, 2023

**Press Release**

EKPO secures large-scale contract for bipolar plates from global car manufacturer

Dettingen/Erms (Germany), March 20, 2023

EKPO FUEL CELL TECHNOLOGIES

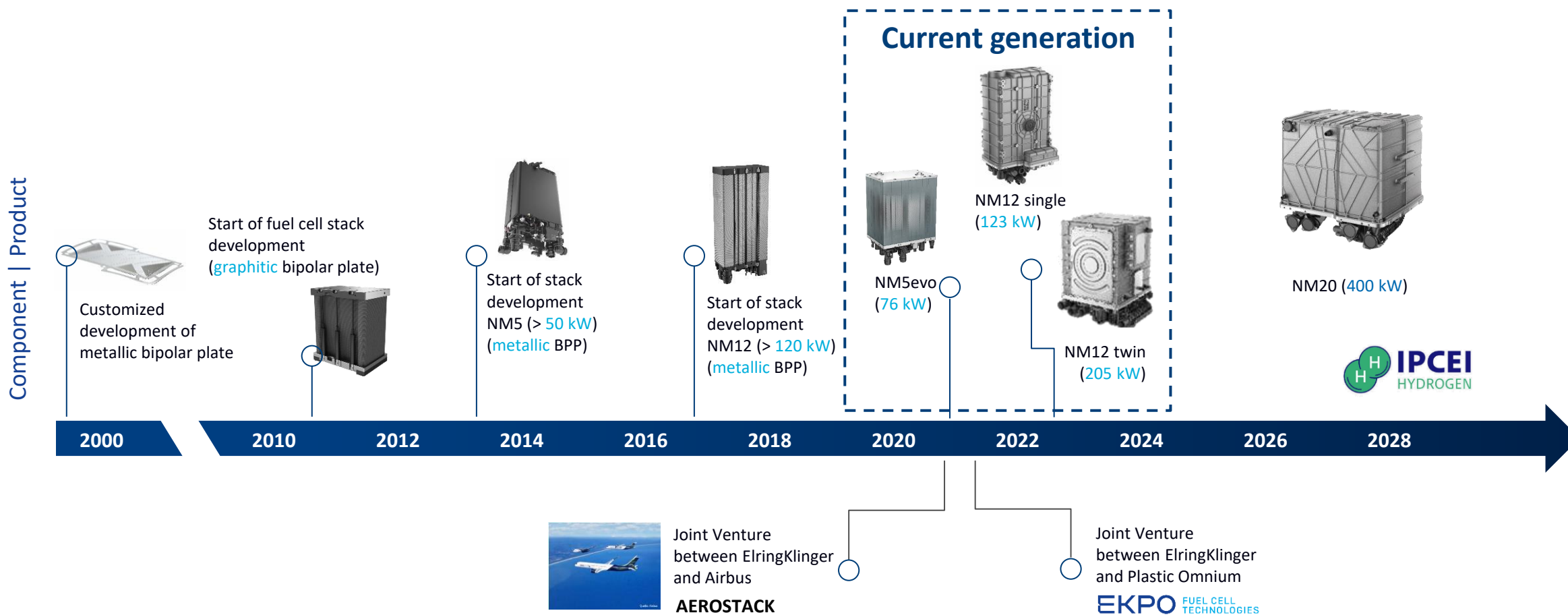

**Dies ist keine offizielle Firmenpräsentation**

EKPO FUEL CELL TECHNOLOGIES

# Global Footprint

## Fort Wayne, USA

EKPO US, since 2023

Bipolar Plate Production  
Fuel Cell Assembly

## Dettingen/Erms, Germany

EKPO Germany, since 2021

### Headquarters

Global R&D and Testing Centre  
Fuel Cell and Bipolar Plate Production

## Suzhou, China

EKPO China, since 2022

Bipolar Plate Production  
Fuel Cell Assembly and Testing

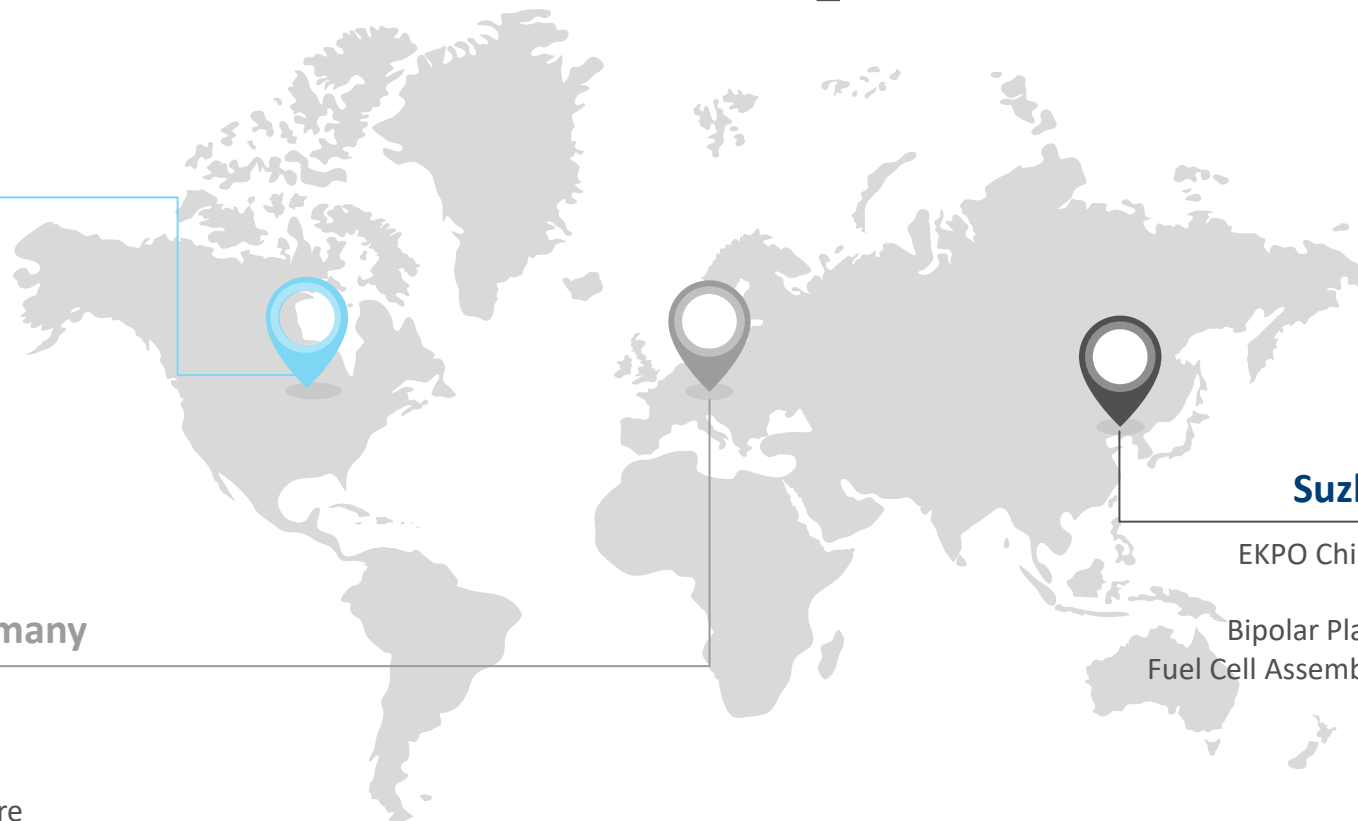

# ▶ SHAPE 30



# SHAPE30 AS ELRINGKLINGER'S ANSWER

TO THE DEMAND OF TODAY  
AND TOMORROW.

## PURPOSE

Why do we need our company?  
What is the deeper goal of the Group beyond profitability?

**PIONEERING  
INNOVATIVE  
TECHNOLOGIES  
FOR A  
SUSTAINABLE FUTURE.**

## VISION

How do we see the future? What is the target picture of our company?

**THE PREFERRED  
PARTNER IN  
DRIVING  
INNOVATIVE  
TECHNOLOGIES.**

## MISSION

What guides our daily actions to make the vision a reality?

**SHAPING THE FUTURE OF  
ELRINGKLINGER BY**

- #1 PRODUCT TRANSFORMATION**
- #2 SUSTAINABILITY**
- #3 PROCESS AND PERFORMANCE EXCELLENCE**
- #4 DIGITAL TRANSFORMATION**
- #5 CORPORATE CULTURE**



#1

PRODUCT  
TRANSFORMATION

#2

SUSTAINABILITY

#3

PERFORMANCE &  
PROCESS EXCELLENCE

#4

DIGITAL  
TRANSFORMATION

#5

CORPORATE  
CULTURE



# #1

## PRODUCT TRANSFORMATION

TRANSFORMING THE  
PRODUCT PORTFOLIO



## OUR GOALS FOR SUCCESS

#1 Product Transformation



ACCOMPLISH TRANSFORMATION  
WITH NON-ICE PRODUCTS TOWARDS  
>50% OF SALES IN 2030



DEVELOPMENT OF E-MOBILITY  
PRODUCTS THAT PROVIDE VALUE  
TO OUR CUSTOMERS



BROADENING OF CUSTOMER  
BASE FOR EXISTING PRODUCTS &  
WIN CONTRACTS

# #2

## SUSTAINABILITY

IMPLEMENTING SUSTAINABLE THINKING  
AND ACTION THROUGHOUT THE GROUP



ECONOMIC SUCCESS COMBINED  
WITH SUSTAINABLE POSITIONING

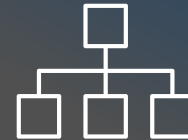

ESTABLISHED ORGANIZATIONAL  
STRUCTURE FOR SUSTAINABILITY



A CLEARLY DEFINED SUSTAINABILITY  
MINDSET WITHIN THE GROUP



RELIABLE AND AUDITABLE ESG DATA

## OUR GOALS FOR SUCCESS

#2 Sustainability

# #3

## PERFORMANCE & PROCESS EXCELLENCE

ACHIEVING PROCESS AND PERFORMANCE  
EXCELLENCE BASED ON STABLE, RELIABLE,  
AND TRANSPARENT PROCESSES



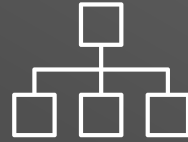

ESTABLISH STABLE, RELIABLE  
AND TRANSPARENT PROCESSES



KPI FOCUS AND PROCESS  
DOCUMENTATION



ALL GROUP KPIS WITHIN TARGETS



ALL FOUR END-TO-END  
PROCESSES ESTABLISHED

## OUR GOALS FOR SUCCESS

#3 Performance &  
Process excellence



# #4

## DIGITAL TRANSFORMATION

ACCELERATING OUR  
DIGITAL TRANSFORMATION

## OUR GOALS FOR SUCCESS

#4 Digital Transformation



DIGITAL BUSINESS PLATFORMS TO  
CONTINUOUSLY KEEP OUR PROCESS  
AND SYSTEM LANDSCAPE AT A  
LEADING MARKET STANDARD



REAL-TIME AND USER-CENTRIC INFORMATION  
FOR INTELLIGENTENABLEMENT



EMPOWERING OUR PEOPLE AT ALL  
LEVELS TO LEVERAGE NEW DIGITAL  
TOOLS AND METHODS

# #5

## CORPORATE CULTURE

EVOLVING A MARKET-ORIENTED CORPORATE CULTURE WITH FOCUS ON INNOVATION AND PERFORMANCE.



## OUR GOALS FOR SUCCESS

#5 Corporate Culture



EK'S CULTURE HAS BEEN FURTHER  
DEVELOPED TOWARDS INNOVATION  
AND COLLABORATION



LEADERSHIP AS CONNECTING  
ELEMENT FOR THE DEVELOPMENT  
OF EK'S COMPANY CULTURE



# VALUES







PURPOSE

VISION

MISSION

#1

#2

#3

#4

#5

VALUES

# Hydrogen: the fear!



→ **WHERE is  
your potential  
leakage???**

[Leckage - Kostenlose industrie-Icons \(flaticon.com\)](https://www.flaticon.com/)

VIELEN DANK

# Mobilität erfahren – Zukunft entwickeln.

# Contact ElringKlinger AG?

**Sven Dieterich:**

**Key Account Manager**



**Telefon +49 7025 912 70 315**

**Mobil +49 152 029 144 11**

**[Sven.Dieterich@elringklinger.com](mailto:Sven.Dieterich@elringklinger.com)**

**[info.de@elringklinger.com](mailto:info.de@elringklinger.com)**